



# DATA SHEET AIR DRAIN TRAP FLOAT PB-350 1"



The PB 350 float steam traps are intended for draining condensate in compressed air and other gases in activities or equipment that require the removal of condensate. Easy maintenance and low cost, KLINGER float traps guarantee efficiency and durability due to their constructive shape, as the KLINGER float trap has a condensate seal that does not allow the passage of gases to the condensate line.

## OPERATION CONDITIONS:

- » OR, maximum operating pressure: 14 bar @ 198 °C - OR 351;
- » OR, maximum operating pressure: 10 bar @ 184 °C - OR 352;
- » OR, maximum operating pressure: 4,5 bar @ 156 °C - OR 353;
- » Maximum housing pressure: 17,6 bar @ 208°C.

## DIAMETERS AND CONNECTIONS:

- » 1";
- » BSP and NPT thread;
- » Integral flanges ANSI B 16.1 125#/250#;
- » Integral flanges ANSI B 16.5 150#/300#.



## MEASURES:

DN	A	B	C-	C-ANSI 125	C-ANSI 250	C-ANSI 150	C-ANSI 300	WEIGHT (KG)
1"	200	24	124	194,4	206	200	220	9,0

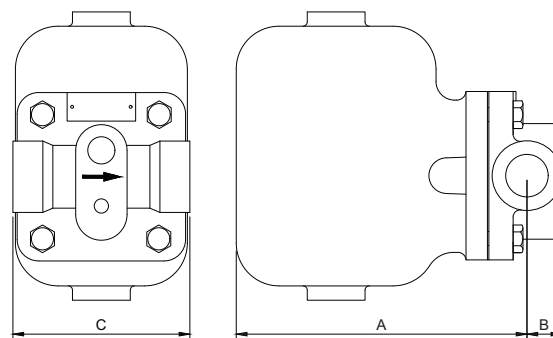

## FLOW CAPACITY

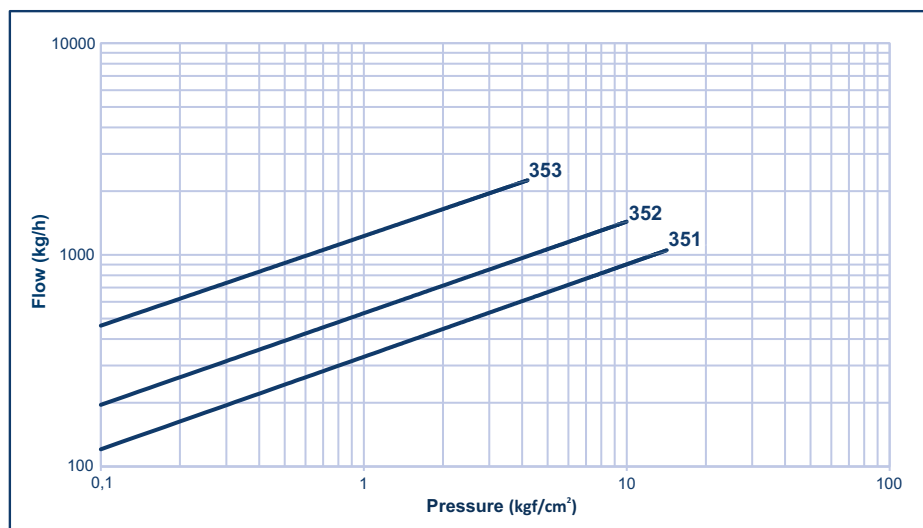



# DATA SHEET AIR DRAIN TRAP FLOAT PB-350 1"



## MATERIAL:

ITEM	DESCRIPTION	MATERIAL
1	Body	Cast iron GGG-40
2	Sealing	Graphite
3	Floater	Stainless steel AISI 304
4	Shutter	Neoprene
5	Support	Stainless steel AISI 304
6	Seat	Stainless steel AISI 304
7	Cap	Cast iron GGG-40
8	Screws	Cast iron

